

Sliding rail assembly procedure

1. Disassemble the slide rail

- Features:
- 3-sections, ball-bearing easy-mount design.
 - pull-out lock
 - load rating 130lbs up
 - 0.5" (12.7mm) thickness
 - 1.8" (46.7mm) height
 - max. ext. to 38" long

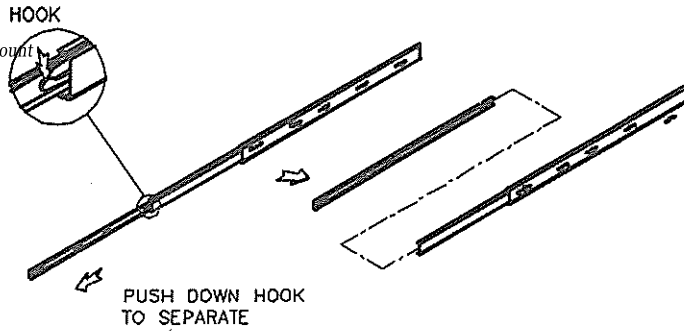

2. Assemble inner rail to chassis

3 hardware bags included:

Fasten 8 screws to fix inner rail on chassis

- bag1: four adjustable brackets (M5 screw hole)
 bag2: Ten #10-32 3/8" standard screws
 bag3: 16* M5x10mm Metric screws
 20* M4x6mm
 10* M4 washer

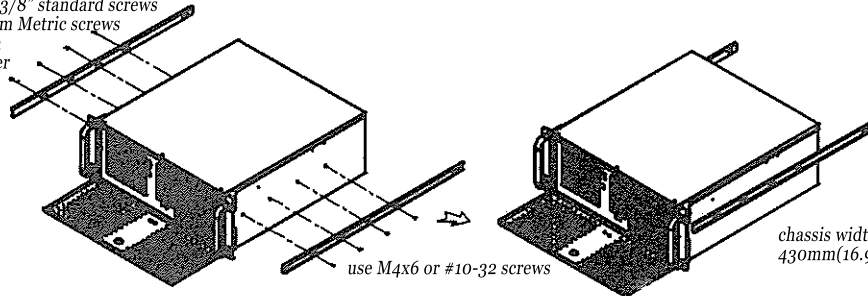

3. Fasten L shape & out piece of rail together

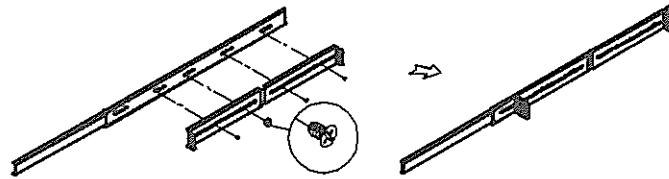

mount the L-brackets w/M4x6 to the tapped holes on outer rails

4. Mount L shape & external rail to rack frame

TYPE A

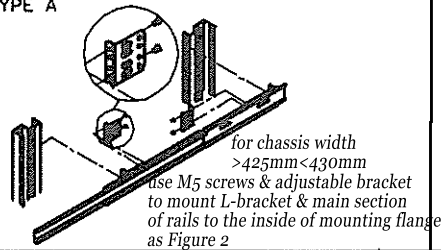

TYPE B

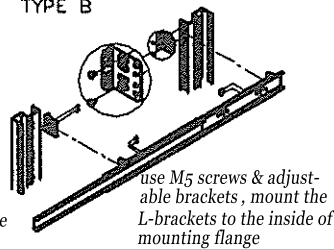

TYPE C

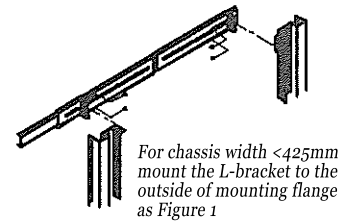

5. Insert chassis to frame

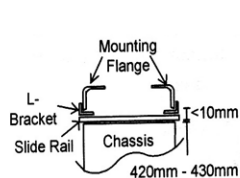

Figure 1

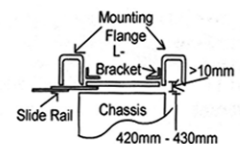
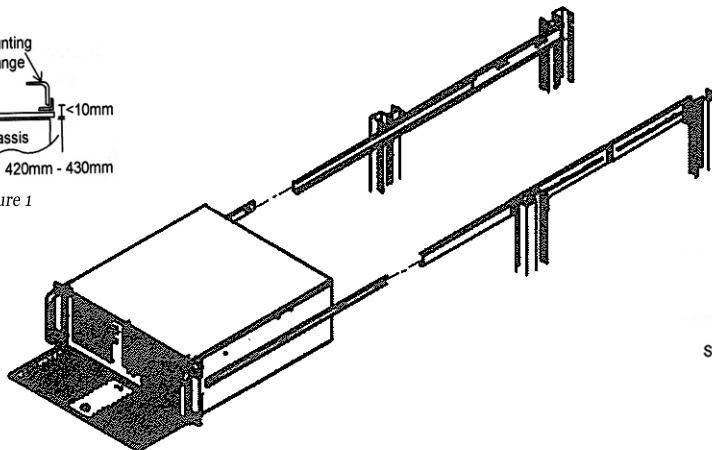

Figure 2